



10×11 BB COUNTER MODEL ELECTRIC

"Serving Those Who Serve The Very Best"®

- **8.9 kW input for cooking up to 40 lbs. of frozen french fries per hour**
- **Instant Recovery® for high production**
- **Stainless Steel cabinet**
- **Polished Stainless Steel fryer vessel**
- **Extra large Cold Zone**
- **Saves valuable space without sacrificing production**
- **Save on oil costs/cooks at lower temperatures**

The 10×11 BB Counter Model Fryer is ideal for multi-product use. The 10×11 BB allows you to cook up to 40 lbs. of frozen french fries per hour with an input of 8.9 kW rated at 240 volts.

KEATING SAVES OIL COSTS IN THREE WAYS:

- BETTER FRY POT DESIGN
- LARGER COLD ZONE
- INSTANT RECOVERY®

1. You shouldn't have to wait on the fryer. A properly designed fry pot ensures that the fryer has recovered its temperature before the end of the cooking cycle. Keating "INSTANT RECOVERY"® means continuous performance.
2. The Keating frying vessel is 27% Cold Zone, the food particles collected in the cold zone are unheated and therefore do not carbonize and contribute to premature shortening breakdown.



3. Keating's "INSTANT RECOVERY"® feature means frying at lower temperatures (325° – 335°F) extending oil life while enhancing product quality.

EASY TO CLEAN

Keating uses only 304 stainless steel in its frying vessel design and polishes each vessel. The smoother the surface, the less carbon build-up occurs, making cleaning easier. A full one inch front drain allows easy draining of oil.

SAFETY CONTROLS ENSURE SAFE AND ACCURATE COOKING

The patented and precise thermostat controls cooking temperatures to ± 3°F. Hi-Limit control protects against the oil and fryer overheating. Each fryer goes through a rigorous 100% test before shipping with every component carefully checked. The actual temperature test chart is included with each fryer.

SPECIAL ORDER OPTIONS

Keating gives you the widest range of options to ensure your fryer is exactly suited to your needs.



COUNTER MODEL INSTANT RECOVERY® FRYER

10×11 CM BB E

DESCRIPTION

The Keating Instant Recovery® 10x11 BB Counter Model Fryer consists of a fryer vessel 10"x11" having a splash deck and a splash back installed in a cabinet equipped with heating elements and an automatic temperature control mechanism, all arranged and designed for proper frying of food.

SPECIFICATIONS

Fryer Vessel shall be constructed from 18 gauge stainless steel, shall have a shortening capacity of 30 pounds, shall be equipped with three stainless steel electric elements spaced above the bottom of the vessel so that the bottom is unheated and the food particles collecting in the bottom zone are unheated and therefore do not carbonize. The frying vessel shall be polished to inhibit carbon buildup and facilitate easy clean-up. The bottom of the vessel shall slope toward the front where it shall be equipped with a 1" Teflon core ¼ turn, drain valve, so arranged that the shortening can be drained into a receiving vessel placed in front of the fryer.

Splashdeck shall slope toward the shortening containing vessel. The splash deck shall be made of 16 gauge 304 stainless steel.

Splashback shall be made of 18 gauge 304 stainless steel shall completely cover the side of the flue.

Cabinet: shall be made of 18 gauge stainless steel. The cabinet shall be rigid in construction and shall have four 4" adjustable legs. A door made of 22 gauge 304 stainless steel shall cover

the front of the cabinet and shall extend from the bottom of the fryer to the panel, and above the panel shall be a canopy. The door shall be the full width of the cabinet. No additional space is required for the door to open a full 90 degrees.

Electric Elements to be three, made of polished stainless steel.

Thermostat shall be close range, hydraulic type and be accurate to ±3°F from 300° to 350°F with stainless steel bulb. Application of this thermostat is patented by Keating.

Hi-Limit Control shall be manually resettable type with stainless steel bulb.

Melt Cycle to be standard on "BB" fryers, allowing the safe melting of solid shortening. Fryer is to be left in the Melt Cycle mode until oil completely covers elements.

Indicating Lights & Switches Power on switch, power on light, fry off melt switch.

Standard Accessories to include one pair 4 mesh baskets, grid screen over elements, drain clean out rod, 1"x11½" drain extension and sample of Keating Klenzer and Sea Powder.

Electric Specifications to be 3-wire terminal block, with ground provided for field wiring. (See local codes for supply line requirements.)

Special Order Options may include thermostat seal, portable filter, 2" drain extensions, cover, security package.

MODEL	208V		220V		240V		380V**		480V**		Working Height*	Overall Height	Depth	Width	Ship Wt.
	KW	Amps	KW	Amps	KW	Amps	KW	Amps	KW	Amps					
10x11 CM BB E 208-240/1	6.7	32	7.5	34	8.9	37	7.5	20	8.9	19	19 ¾"	27 ¼"	25 ¼"	12 ¾"	120lbs.
10x11 CM BB E 208-240/3	6.7	19-19-19	7.5	20-20-20	8.9	21-21-21	7.5	11-11-11	8.9	11-11-11	19 ¾"	27 ¼"	25 ¼"	12 ¾"	120lbs.

Oil Capacity - 30 lbs.

*Denotes height from top of counter to top of fryer deck.

**380V or 480V are special order options.

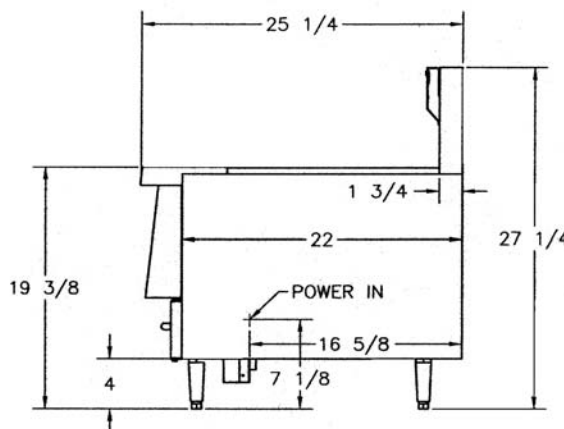
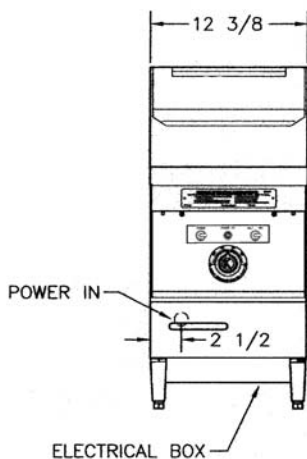

KEATING OF CHICAGO, INC.
Toll Free 1-800-KEATING
www.keatingofchicago.com