



20 INCREDIBLE FRYING MACHINE® GAS

"Serving Those Who Serve The Very Best"®

- 118,000 BTU input for cooking up to 140 lbs. of frozen french fries per hour
- Instant Recovery® for high production
- Save up to 40% in energy costs
- New burner technology
- Low flue temperatures keeps kitchen cooler
- Stainless Steel cabinet
- Polished Stainless Steel fryer vessel
- Cold Zone 27% of fryer vessel
- Save on oil costs/cooks at lower temperatures
- Indicating lights and timers
- Easy one button On/Off operation
- Instant-On™ System

The Keating 20 INCREDIBLE FRYING MACHINE® high efficiency, high production fryer with new burner technology lets you cook 140 lbs. of frozen fries or 200 lbs. of chicken per hour with an input of only 118,000 BTU. The Instant-On™ System, anticipates large loads to handle peak cooking requirements. Easy to operate, the 20 IFM is equipped with indicating lights which tell the status of the fryer at all times. Two digital display timers with repeat memories ensure precise cooking times.

SAVE ON ENERGY COSTS

The exclusive burner design coupled with the patented heat reclamation baffle ensure optimum heat transfer while saving up to 40% in energy costs over atmospheric burner models.

KEATING SAVES OIL COSTS IN THREE WAYS:

- BETTER FRY POT DESIGN
- LARGER COLD ZONE
- INSTANT RECOVERY®

1. You shouldn't have to wait on the fryer. A properly designed fry pot ensures that the fryer has recovered its temperature before the end of the cooking cycle. Keating "INSTANT RECOVERY"® means continuous performance.



Casters Optional

2. The Keating frying vessel is 27% Cold Zone, the food particles collected in the cold zone are unheated and therefore do not carbonize and contribute to premature shortening breakdown.
3. Keating's "INSTANT RECOVERY"® feature means frying at lower temperatures (325°– 335°F) extending oil life while enhancing product quality.

EASY TO CLEAN

Keating uses only 304 stainless steel in its frying vessel design and polishes each vessel. The smoother the surface, the less carbon build-up occurs, making cleaning easier. A full 1 1/4" front drain allows easy draining of oil.

SAFETY CONTROLS ENSURE SAFE AND ACCURATE COOKING

The patented and precise thermostat controls cooking temperatures to ±3°F. Hi-Limit control protects against the oil and fryer overheating.

Each fryer goes through a rigorous 100% test before shipping with every component carefully checked. The actual temperature test chart is included with each fryer.

SPECIAL ORDER OPTIONS

Keating gives you the widest range of options to ensure your fryer is exactly suited to your needs.



INCREDIBLE FRYING MACHINE®

20 IFM GAS

DESCRIPTION

The Keating 20 IFM Fryer consists of a frying vessel 20" sq., having a splash deck and a splash back installed in a cabinet equipped with gas burners and an automatic temperature control mechanism, all arranged and designed for the proper frying of food.

SPECIFICATIONS

Frying Vessel: shall have be constructed from 18 gauge stainless steel, shall have a shortening capacity of 100 pounds, shall be equipped with four 18 gauge horizontal heat transfer tubes spaced above the bottom of the vessel so that the bottom is unheated and the food particles collecting in this bottom zone are unheated and therefore do not carbonize. The frying vessel shall be polished to inhibit carbon build-up and facilitate easy clean-up. The heat transfer tubes shall be 3" wide and 5" high. The bottom of the vessel shall slope toward the front where it shall be equipped with a 1 1/4" Teflon core 1/4 turn, drain valve, so arranged that the shortening can be drained into a receiving vessel placed in front of the fryer.

Splashdeck shall slope toward the shortening containing vessel. **The splash deck shall be made of 16 gauge 304 stainless steel.**

Splashback shall be made of 18 gauge 304 stainless steel, shall completely cover the sides of the flue.

Cabinet: Shall be made of 18 gauge stainless steel. The cabinet shall be rigid in construction and shall have four 8" adjustable legs. A door made of 22 gauge 304 stainless steel shall cover the front of the cabinet and shall extend from the bottom of the fryer to the panel, and above the panel shall be a canopy. The door shall be the full width of the cabinet. No additional space is required for the door to open a full 90 degrees. A stainless steel flue deflector is to be provided for installing onto the flue back.

Electronic Ignition automatically lights burners. There is no standing pilot to struggle to light.

Burners to be two inconel mesh tubular style encased in ceramic cloth with rated output of 59,000 BTU/hr. natural gas per burner.

Heat Transfer Tubes to be four, made of stainless steel polished to a #7 mirror finish. The middle tubes have a patent applied for recycle baffle inside to increase efficiency.

Timers to be two electronic, settable from 0 to 99 minutes with memory repeat and Instant-On™ Start System.

Thermostat shall be close range, hydraulic type and be accurate to ±3°F from 300° to 350°F with stainless steel bulb. Application of this thermostat is patented by Keating.

Hi-Limit Control shall be manually resettable type with stainless steel bulb.

100% Safety Shut Off shall be electronic with combination control gas valve.

Indicating Lights & Switches. "On-Off" switch, Power On indicating light (white), blower on indicating light (blue), burner on indicating light (amber), ready to fry light (green), over max temp light (red).

Standard Accessories to include one pair 4 mesh baskets, grid screen over heat transfer tubes, drain clean out rod and sample of Keating Klenzer and Sea Powder.

Electrical Requirements: Supply Voltage 120V 60Hz. Control Voltage 24V 60Hz. 120 VAC 9ft. (1.5 m) grounded cord set provided.

Gas Requirements to install are 3/4" male NPT connection and 3" water column pressures natural and 10" for LP gas at the fryer burner manifold. Supply pressure to fryers must be 7" (natural gas) and 11" (LP) water column.

Special Order Options may include battery, common manifold, casters, cover, central filter (CF20SE or above), Safe & Easy filter, security package, basket-lift, computer, triple size baskets, 2" drain valve (not available on SE).

Model No. and Description	Oil Capacity	BTU Input	Height	Depth	Width	Ship Wt.
20 IFM Nat Gas	100 lbs.	118,000	46 1/2"	37 1/4"	21 3/8"	260 lbs.
20 IFM LP Gas	100 lbs.	118,000	46 1/2"	37 1/4"	21 3/8"	260 lbs.
20 Safe & Easy	-	-	46 1/2"	38 5/8"	21 3/8"	-

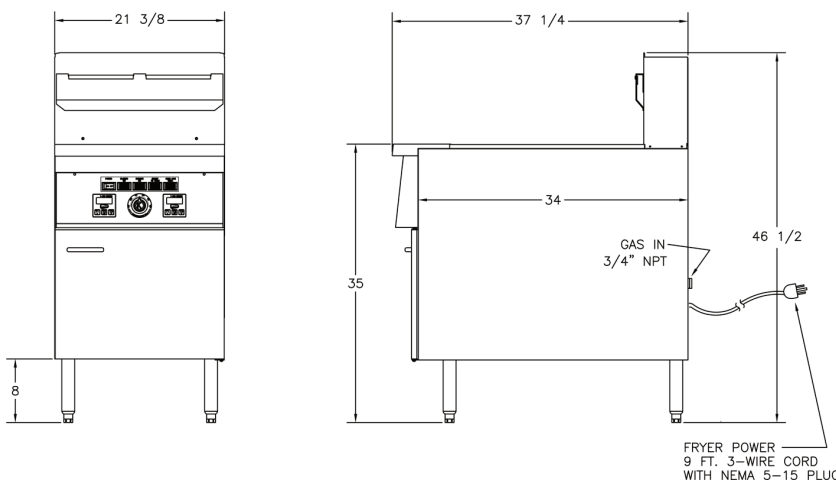

KEATING OF CHICAGO, INC.
Toll Free 1-800-KEATING
www.keatingofchicago.com

As continuous product improvement occurs, specifications may be changed without notice.