

"Serving Those Who Serve The Very Best"®

- **201,000 BTU input for cooking up to 270 lbs. of frozen french fries per hour**
- **Instant Recovery® Fryer now even more efficient using less energy with our newly patented Wing Turbulators®**
- **Stainless Steel cabinet**
- **Polished Stainless Steel fryer vessel**
- **Extra large Cold Zone**
- **Saves on oil costs/cooks at lower temperatures**
- **Indicating lights**
- **Melt cycle standard**

The 34x24 BB Fryer is ideal for multi-product use. The 34x24 BB allows you to cook up to 270 lbs. of frozen french fries or 300 lbs. of chicken per hour with an input of 201,000 BTU.

KEATING SAVES OIL COSTS IN THREE WAYS:

BETTER FRY POT DESIGN
LARGER COLD ZONE
INSTANT RECOVERY®

1. You shouldn't have to wait on the fryer. A properly designed fry pot ensures that the fryer has recovered its temperature before the end of the cooking cycle. Keating "INSTANT RECOVERY"® means continuous performance.
2. The Keating frying vessel is 27% Cold Zone, the food particles collected in the cold zone are unheated and therefore do not carbonize and contribute to premature shortening breakdown.



Casters Optional

3. Keating's "INSTANT RECOVERY"® feature means frying at lower temperatures (325° - 335°F) extending oil life while enhancing product quality.

EASY TO CLEAN

Keating uses only 304 stainless steel in its frying vessel design and polishes each vessel. The smoother the surface, the less carbon build-up occurs, making cleaning easier. A full two 1/4" front drain allows easy draining of oil.

SAFETY CONTROLS ENSURE SAFE AND ACCURATE COOKING

The patented and precise thermostat controls cooking temperatures to ± 3°F. Hi-Limit control protects against the oil and fryer overheating.

Each fryer goes through a rigorous 100% test before shipping with every component carefully checked. The actual temperature test chart is included with each fryer.

SPECIAL ORDER OPTIONS

Keating gives you the widest range of options to ensure your fryer is exactly suited to your needs.

DESCRIPTION

The Keating Instant Recovery® 34x24 BB Fryer consists of a frying vessel 34"x24" having a splash deck and a splash back installed in a cabinet equipped with gas burners and an automatic temperature control mechanism, all arranged and designed for the proper frying of food.

SPECIFICATIONS

Frying Vessel: shall be constructed from 18 gauge stainless steel, shall have a shortening capacity of 195 pounds, shall be equipped with six 18 gauge horizontal heat transfer tubes spaced above the bottom of the vessel so that the bottom is unheated and the food particles collecting in this bottom zone are unheated and therefore do not carbonize. The frying vessel shall be polished to inhibit carbon build-up and facilitate easy clean-up. The heat transfer tubes shall be 3" wide and 5" high. The bottom of the vessel shall slope toward the front where it shall be equipped with two 1 1/4" Teflon core 1/4 turn, drain valve, so arranged that the shortening can be drained into a receiving vessel placed in front of the fryer.

Splashdeck shall slope toward the shortening containing vessel. **The splash deck shall be made of 16 gauge 304 stainless steel.**

Splashback shall be made of 18 gauge 304 stainless steel, shall completely cover the sides of the flue.

Cabinet: shall be made of 18 gauge stainless steel. The cabinet shall be rigid in construction and shall have four 8" adjustable legs. Two doors made of 22 gauge 304 stainless steel shall cover the front of the cabinet and shall extend from the bottom of the fryer to the panel, and above the panel shall be a canopy. Each door shall be one-half of the width of the cabinet. No additional space is required for the door to open a full 90 degrees. A stainless steel flue deflector is provided for installing onto the flue back.

Heat Transfer Tubes to be six, made of stainless steel polished to a #7 mirror finish.

Thermostat shall be close range, hydraulic type and be accurate to ±3°F from 300° to 375°F with stainless steel bulb. Application of this thermostat is patented by Keating.

Hi-Limit Control shall be manually resettable type with stainless steel bulb.

100% Safety Shut Off shall be flame switch type with dual combination control gas valve.

Melt Cycle shall be standard on "BB" fryers, allowing the safe melting of solid shortening. Fryer is to be left in the Melt Cycle mode until oil completely covers heat transfer tubes.

Indicating Lights & Switches. Power on switch, power on light, pilot switch, pilot on light, fry off melt switch.

Standard Accessories to include one pair split size 4 mesh baskets, one triple size 4 mesh basket, grid screen over heat transfer tubes, drain clean out rod and sample of Keating Klenzer and Sea Powder.

Electrical Connections to be 120V 1 amp, supplied with cord and 3 pronged plug.

Gas Requirements to install are 3/4" male NPT connection and 4" water column pressures natural and 10" for LP gas at the fryer burner manifold. Supply pressure to fryers must be 7" (natural gas) and 11" (LP) water column.

Special Order Options may include battery, common manifold, rear drain, casters, cover, thermostat seals, portable filter, central filter (CF34x24SE), Safe & Easy filter, security package, spark ignition.

Model No. and Description	Oil Capacity	BTU Input	Height	Depth	Width	Ship Wt.
34x24 BB Nat Gas	195 lbs.	201,000	46 1/2"	38 1/2"	35 3/8"	460 lbs.
34x24 BB LP Gas	195 lbs.	198,000	46 1/2"	38 1/2"	35 3/8"	460 lbs.
34x24 Safe & Easy	-	-	46 1/2"	42 5/8"	35 3/8"	-

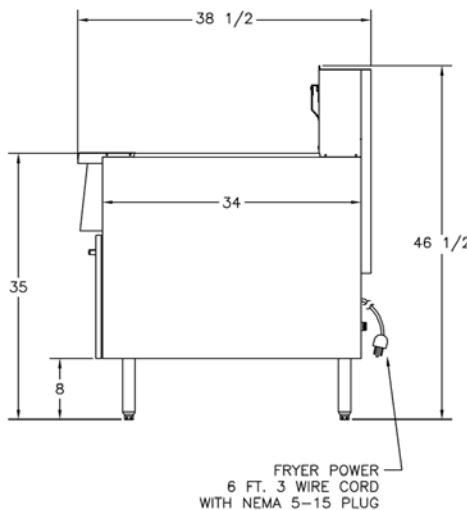
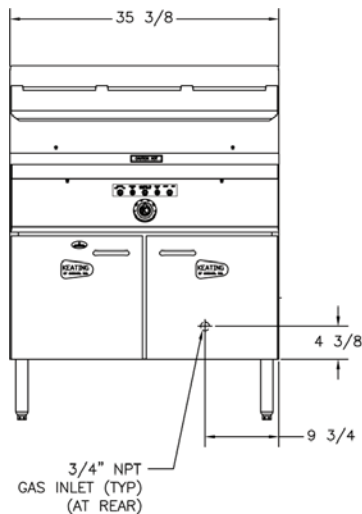

KEATING OF CHICAGO, INC.
Toll Free 1-800-KEATING
www.keatingofchicago.com

As continuous product improvement occurs, specifications may be changed without notice.

