



Model No. 14 TS G  
Basket-Lift  
Instant Recovery® Fryer

PROJECT \_\_\_\_\_

QUANTITY \_\_\_\_\_

ITEM NO. \_\_\_\_\_

**Standard Features:**

- ▶ 87,000 BTU input for cooking up to 72 lbs. of frozen french fries per hour
- ▶ Automatically lowers and raises basket at the beginning and end of timed cooking cycle
- ▶ Instant Recovery® using less energy with more efficient, patented Wing Turbulators®
- ▶ Stainless Steel cabinet
- ▶ Polished Stainless Steel drawn pot with seamless coved corners uses 24% less oil
- ▶ Extra large Cold Zone
- ▶ Saves on oil costs/cooks at lower temperatures
- ▶ Indicating lights and timers
- ▶ Melt cycle allows safe method of melting solid shortening

**Options:**

- |  |   |
|--|---|
| <input type="checkbox"/> Instant-On™     | <input type="checkbox"/> Thermostat Seal                                      |
| <input type="checkbox"/> Spark Ignition  | <input type="checkbox"/> Portable Filter, Central Filter, Safe & Easy® Filter |
| <input type="checkbox"/> Computer        | <input type="checkbox"/> Security Package                                     |
| <input type="checkbox"/> Battery         | <input type="checkbox"/> Cover  |
| <input type="checkbox"/> Common Manifold |   |
| <input type="checkbox"/> Rear Drain      |   |
| <input type="checkbox"/> Casters         |   |



Casters Optional

The 14 TS Basket-Lift Fryer is ideal for multi-product use. The 14 TS Basket-Lift allows you to cook up to 72 lbs. of frozen french fries or 75 lbs. of chicken per hour with an input of 87,000 BTU.

**Keating saves oil costs in three ways:**

- BETTER FRY POT DESIGN
- LARGER COLD ZONE
- INSTANT RECOVERY®

1. The seamless coved corners of the deep drawn frying vessel with built-in elements requires 24% less oil while giving the production of a 50 lb. fryer.
2. The Keating frying vessel is 27% Cold Zone, the food particles collected in the cold zone are unheated and therefore do not carbonize and contribute to premature shortening breakdown.
3. Keating's "INSTANT RECOVERY"® feature means frying at lower temperatures (325° – 335°F) extending oil life while enhancing product quality.

• **Oil Capacity - 38 lbs.**

**Easy to clean**

Keating uses only 304 stainless steel in its frying vessel design and polishes each vessel. The smoother the surface, the less carbon build-up occurs, making cleaning easier. A full one inch front drain allows easy draining of oil. Safety controls ensure safe and accurate cooking. The patented and precise thermostat controls cooking temperatures to ± 3°F. Hi-Limit control protects against the oil and fryer overheating.

Each fryer goes through a rigorous 100% test before shipping with every component carefully checked. The actual temperature test chart is included with each fryer.

**Special Order Options**

Keating gives you the widest range of options to ensure your fryer is exactly suited to your needs.



As continuous product improvement occurs, specifications may be changed without notice.

DATE \_\_\_\_\_

APPROVAL \_\_\_\_\_

SIGNATURE \_\_\_\_\_

[www.keatingofchicago.com](http://www.keatingofchicago.com)

14 TS Gas Basket-Lift Instant Recovery® Fryer

"Serving Those Who Serve The Very Best"®

**KEATING**  
OF CHICAGO, INC.

Model No. 14 TS G Basket-Lift  
Instant Recovery® Fryer

A minimum of 24" at the front of the unit should be allowed for servicing and operation; a minimum of 6" on each side and at the rear of each unit for combustible materials.

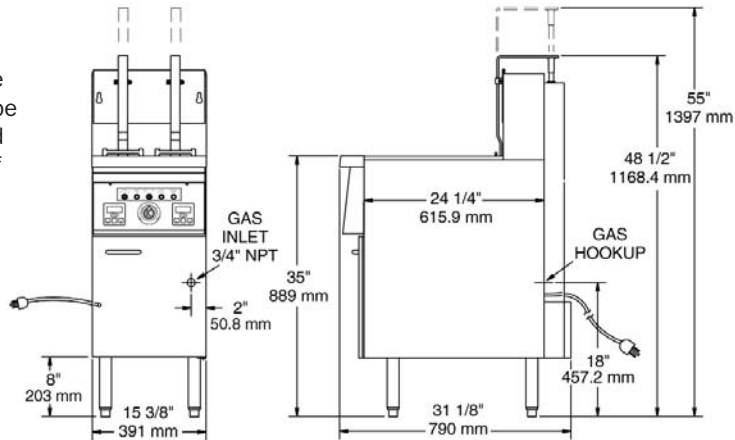

**SPECIFICATIONS**

**Fryer Vessel** - 18 gauge stainless steel with covered seamless corners and a shortening capacity of 38 pounds. Equipped with three 18 gauge stainless steel, 3" wide x 5" high horizontal heat transfer tubes, spaced above the bottom of the vessel so that the bottom is unheated and the food particles collecting in the bottom zone are unheated and therefore do not carbonize. The vessel is polished to inhibit carbon buildup and facilitate easy clean-up. The bottom of the vessel slopes toward the front, and is equipped with a 1" Teflon core 1/4 turn drain valve, so the shortening can be drained into a receiving vessel placed in front of the fryer.

**Splashdeck** - 16 gauge, 304 stainless steel. It slopes toward the shortening containing vessel.

**Splashback** - 18 gauge, 304 stainless steel. It completely covers the side of the flue.

**Cabinet** - 18 gauge stainless steel. Rigid in construction, with four 8" adjustable legs. The cabinet door is made of 22 gauge 304 stainless steel. The door covers the front of the cabinet from the bottom of the fryer to the fryer panel, and the full width of the cabinet. Above the panel is a canopy. No additional space is required for the door to open a full 90 degrees. A stainless steel flue deflector is provided for installing onto the flue back.

**Heat Transfer Tubes** - Three heat transfer tubes, made of stainless steel polished to a #7 mirror finish.

**Thermostat** - Close range, hydraulic type, is accurate to ±3°F from 300° to 350°F with stainless steel bulb. Application of this thermostat is patented by Keating.

**INSTALLER** - Check plumbing and gas codes for proper gas supply line sizing to sustain burner pressure when all gas appliances are full on. Supply pressure must NOT be above 13.84" WC or gas valve damage may occur.

**Hi-Limit Control** - Manually resettable type with stainless steel bulb.

**100% Safety Shut-Off** - Flame switch type with combination control gas valve.

**Melt Cycle** - Standard on "TS" fryers, allowing the safe melting of solid shortening. Fryer is to be left in the Melt Cycle mode until oil completely covers heat transfer tubes.

**Indicating Lights & Switches** - Power on, push to light switch, fry/off/melt switch, ready to cook light, over max temp light.

**Basket-Lift** - Controlled by two electric timers, one for each basket. Baskets are lowered with the push of a button and are raised automatically at the end of the preset time. A buzzer signals the end of cooking cycle.

**Standard Accessories** - Includes two timers (programmable for three products each), one pair 4 mesh baskets, grid screen over heat transfer tubes, drain clean out rod and sample of Keating Klenzer.

**Electrical Requirements** - Supply Voltage 120V 60Hz, Control Voltage 24V 60 Hz, 120 VAC 9' (1.5m) grounded cord set provided.

**Gas Requirements** - Install a 3/4" male NPT connection and 4" water column pressure (natural gas) and 10" (LP) at the fryer burner manifold. Supply pressure to fryers must be 7" (natural gas) and 11" (LP) water column.

**Special Order Options** may include Instant-On™, computer, spark ignition, battery, common manifold, rear drain, casters, thermostat seal, cover, portable filter, central filter (CF14SE), Safe & Easy® Filter and security package.

**GAS REQUIREMENTS / DIMENSIONS**

MODEL	BTU Input	Height	Depth	Width	Weight
14 TS BL Natural Gas	87,000	55"	30 1/4"	15 3/8"	215 lbs.
14 TS BL LPGas	90,000	55"	30 1/4"	15 3/8"	215 lbs.

As continuous product improvement occurs, specifications may be changed without notice.

[www.keatingofchicago.com](http://www.keatingofchicago.com)

14 TS Gas Basket-Lift Instant Recovery® Fryer