



Portable Filter

PROJECT _____

QUANTITY _____

ITEM NO. _____

Standard Features:

- ▶ Designed for use with any front drain fryer model
- ▶ Provides safe filtration while easy to use
- ▶ High speed pump
- ▶ Filters oil in less than 2 minutes
- ▶ Saves on oil costs
- ▶ Improves product quality
- ▶ Built-In melt cycle

Options:

- Two Way Pump (LB Models)
- Strainer Basket
- 220V on LB 100 (special order, not certified)
- Cover (PC 14)



Model LB 200-2

The Keating Portable Filter is designed to minimize oil breakdown and extend oil life. Built for use with appropriately sized front drain fryer models, the Portable Filter is easily maneuvered and can be rolled away for storage.

Save on oil costs

Keating's Nutroilator® System combines the advantages of low temperature cooking, Cold Zone sedimentation and a one-step, multi-layered filter to purify oil. Cooking temperature, moisture and oxidation are the main causes of oil breakdown. Nutroilation conditions oil and removes free fatty acids, which if done on a regular basis, extends the life of the oil.

Fast and easy filtration

The high capacity pump filters five gallons of oil per minute. Simply roll Keating's Portable Filter under the fryer drain valve and place hose in fryer vessel. Empty oil into filter vessel, close drain valve and switch on filter pump while holding the hose nozzle. Crumbs, debris and contaminants are removed and oil is purified. When solidified shortening is present, the built-in melt cycle safely melts it to prevent it from clogging the filter.

Effectively removes food particles

The multi-layered filtration system removes food particles. The optional strainer basket separates large crumbs from the oil and traps them before entering the filter. The remaining oil is conditioned by Keating's Acidox filtering compound to remove fatty acids and then pumped through filter paper to remove any remaining debris.

Durable construction ensures safe filtering

The deep stainless steel construction of the filter vessel safely holds hot oil during filtration. The heavy duty handle and polyurethane casters give you more control while maneuvering the filter. The 5-ft hose has an adjustable angled nozzle with safety handle to safely pump filtered oil.



As continuous product improvement occurs, specifications may be changed without notice.

DATE _____

APPROVAL _____

SIGNATURE _____

www.keatingofchicago.com

Portable Filter



Portable Filter

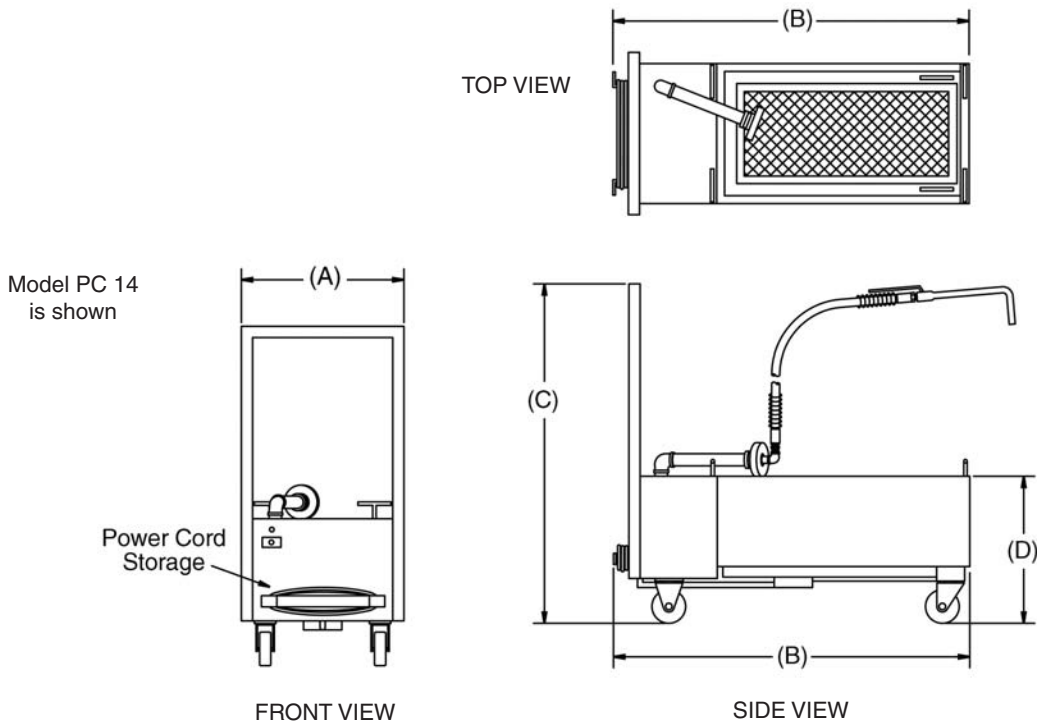

SPECIFICATIONS

Filter Vessel - 18 gauge Stainless Steel with an enclosed sump. Filter vessel is polished to a #7 mirror Stainless Steel finish to inhibit carbon buildup and facilitate easy cleaning. The vessel on the LB unit is seamless.

Cabinet - 18 gauge Stainless Steel mounted on four adjustable polyurethane casters. Heavy duty handle is designed for easy portability.

Melt Cycle - Activates the heat plates and heat tape to liquefy any solidified shortening. A sensor prevents temperature from exceeding a preset value.

Filter Paper - Exclusively designed to fit in filter tub.

Hold Down Ring - Keeps filter paper in place and holds Acidox filtering compound.

Pump - 1/3 horsepower, rated at pumping five gallons of oil per minute.

Hose - 5' long hose with swivel handle and stiffener spring. A nozzle is provided for returning oil to fryer or discarding. Models with two way pumps can also remove hot oil directly from fryer vessel without using the fryer drain valve.

Standard Accessories - Filter cover (LB models), removable 6' cords (LB models), stiffener spring, one package of filter paper (60 sheets) and one carton of Acidox filter compound (60 packages).

Electrical Requirements - 120V, 5.6 amps for the pump circuit or up to 120V, 9.6 amps for the melt circuit. Filter is supplied with a 6' neoprene cord with a 3-pronged grounded plug.

Special Order Options may include two way pump (on LB models), strainer basket, 220V is available (special order - not certified) LB 100, cover (PC 14).

MODEL	Compatible With Fryer	Oil Capacity	Voltage	HP	Amps* @ 120V HP	(A) Width	(B) Depth	(C) Overall Height	(D) Drawer Height	Weight
LB 100	10x11-20	100 lbs.	120	1/3	9.9	21 3/4"	31 1/8"	22 7/8"	13 7/8"	185 lbs.
LB 165	24	165 lbs.	120	1/3	9.6	28 3/8"	37 3/8"	22 3/8"	12 5/8"	220 lbs.
LB 200	34x24	200 lbs.	120	1/3	9.6	30 3/8"	39 3/8"	22 5/8"	14 1/8"	275 lbs.
PC 14	10x11-14	48 lbs.	120	1/3	9.2	14 1/2"	31 1/4"	30 1/4"	13 1/8"	110 lbs.

*Filter unit uses Amps shown on Melt Cycle or 5.6 Amps when on Pump Cycle.

As continuous product improvement occurs, specifications may be changed without notice.

www.keatingofchicago.com

Portable Filter