



# Salting / Bagging Station

PROJECT \_\_\_\_\_

QUANTITY \_\_\_\_\_

ITEM NO. \_\_\_\_\_

**Standard Features:**

- ▶ All-in-one prep and serving area
- ▶ Heated display station keeps foods fresh with Keating Keep Krisp® Food Warmers
- ▶ Bagging station (specify right or left side)
- ▶ All Stainless Steel construction
- ▶ 2 large storage shelves

**Options:**

- Flat Top
- Casters



Unit shown with optional 12 x 20 pan and french fry holder.

Keating's Salting / Bagging Station features a convenient preparation area as well as a heated holding and display station. The durable design and Stainless Steel construction allows you to easily serve a wide variety of foods such as french fries, chicken, fish and many more items. The Salting / Bagging Station features Keating Keep Krisps® to keep foods hot and fresh prior to serving. Also available with a flat top, the Salting / Bagging Station gives you more flexibility during your prep time.

**Keep Krisp® Food Warmers**

The 30" Salting / Bagging Station comes complete with four Keep Krisp® bulbs for 1000 watts of heating, perfect for keeping foods hot, crisp and fresh. The larger 36" Station is equipped with six Keep Krisp® bulbs.

**Mirrored back wall**

To keep a clean and appetizing appearance for your customers, the Salting / Bagging Station is built with highly polished stainless steel and has a mirrored backwall for added shine and lustre.

**Large dump pan**

A large 15" x 20" perforated dump area.

**Convenient storage area**

Two shelves located below the unit give extra storage room to stack bags, tongs, salt shakers, and other supplies.



As continuous product improvement occurs, specifications may be changed without notice.

DATE \_\_\_\_\_

APPROVAL \_\_\_\_\_

SIGNATURE \_\_\_\_\_

[www.keatingofchicago.com](http://www.keatingofchicago.com)

Salting / Bagging Station



## Salting / Bagging Station

### 30" Salting / Bagging Station

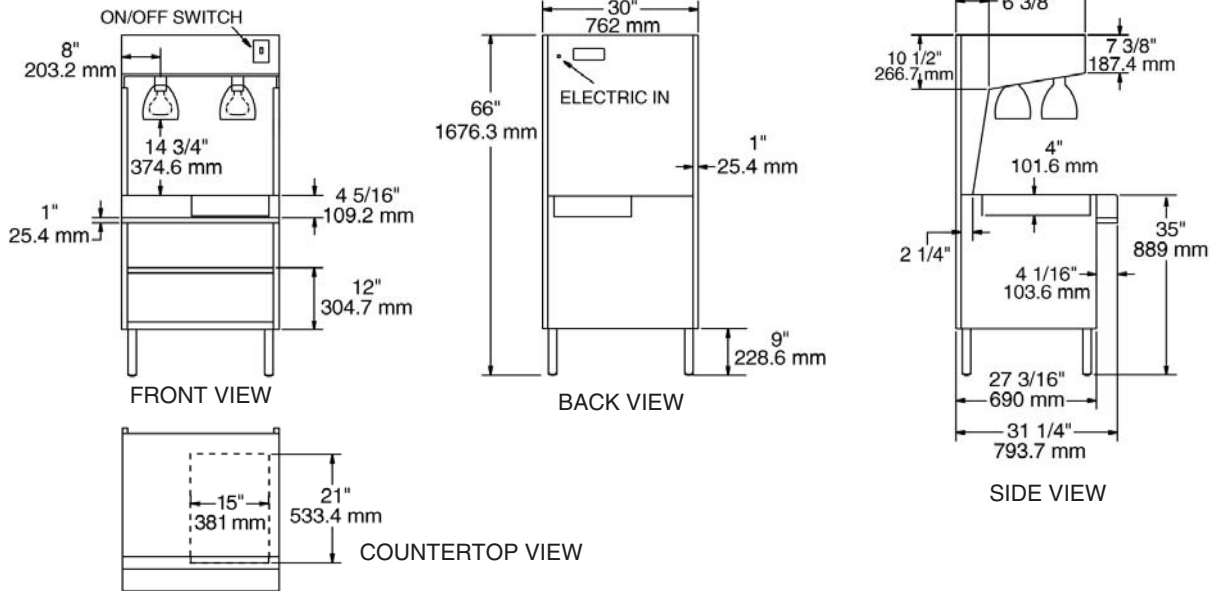

### 36" Salting / Bagging Station

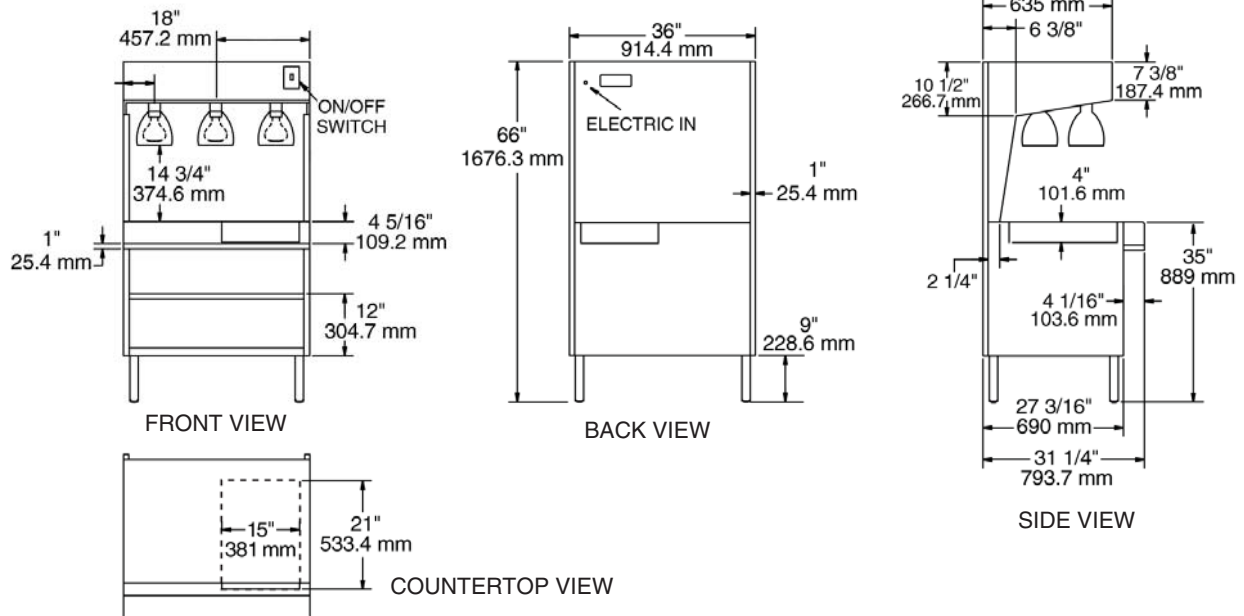

#### ELECTRICAL REQUIREMENTS / DIMENSIONS

MODEL	Keating Keep Krisp®	Amps @ 120V	Width	Depth	Height	Weight
30" Salting / Bagging Station	4	8	30"	31 1/4"	66"	330 lbs.
36" Salting / Bagging Station	6	12	36"	31 1/4"	66"	360 lbs.

Electrical Connection - 6' cord with 3-prong plug.

As continuous product improvement occurs, specifications may be changed without notice.

[www.keatingofchicago.com](http://www.keatingofchicago.com)

Salting / Bagging Station