



Safe & Easy[®] Central Filter

PROJECT _____

QUANTITY _____

ITEM NO. _____

Standard Features:

- ▶ Closed, “hands-free” system provides safe and easy filtration
- ▶ Space saving design
- ▶ High speed pump
- ▶ Filters oil in less than 2 minutes
- ▶ Saves on oil costs
- ▶ Improves product quality
- ▶ Available with 34x24 fryers

Options:

- Keep Krisp[®] Food Warmer mounted over prep area
- Heat tape for solid shortening
- 220V (special order, not certified)



Casters on Fryer are Optional

Common installation: 18” Safe & Easy Central Filter with three 18 TS BL Fryers and optional Flat Top preparation area.

The Safe & Easy[®] Central Filter is designed to minimize oil breakdown and extend oil life. The closed “hands-free” system means that you never come in contact with hot oil during the filtration process. Completely contained within its own cabinet, Keating’s Safe & Easy[®] Central Filter assures safe and proper handling of hot oil.

Save on oil costs

The Safe & Easy[®] system combines the advantages of low temperature cooking, Cold Zone sedimentation and a one-step, multi-layered filter to purify oil. Cooking temperature, moisture and oxidation are the main causes of oil breakdown. Filtering conditions oil and removes free fatty acids, which if done on a regular basis, extends the life of the oil.

Fast and easy filtration

The high capacity pump filters five gallons of oil per minute. Simply open the drain valve, switch on the filter pump and close the drain valve. The Safe & Easy[®] Central Filter does the rest. With the patented swirling action, crumbs, debris and contaminants are removed and oil is purified. When solidified shortening is present, the optional melt cycle safely melts it to prevent it from clogging the filter.

Effectively removes food particles

The multi-layered filtration system removes food particles. The strainer basket separates large crumbs from the oil and traps them before entering the filter. The remaining oil is conditioned by Keating’s Acidox Filtering Compound to remove fatty acids and then pumped through filter paper to remove any remaining debris. Simply dump the crumbs and lift out the paper to complete the filtering process.

Fast and convenient

With no additional equipment to store, no special attachments to put in place and no special steps to rinse down the fryer, the Safe & Easy[®] Central Filter helps you filter quickly and without hassle. Depending on your fryer size, five minutes is all you need. When filtering a battery of fryers, you can filter one fryer while the others are still in operation for non-stop production.



Intertek
9902091



Intertek
9902091



As continuous product improvement occurs, specifications may be changed without notice.

DATE _____

APPROVAL _____

SIGNATURE _____

www.keatingofchicago.com

Safe & Easy[®] Central Filter



Safe & Easy® Central Filter

14" Safe & Easy®
Central Filter
shown with optional
Recessed
Bagging Station.

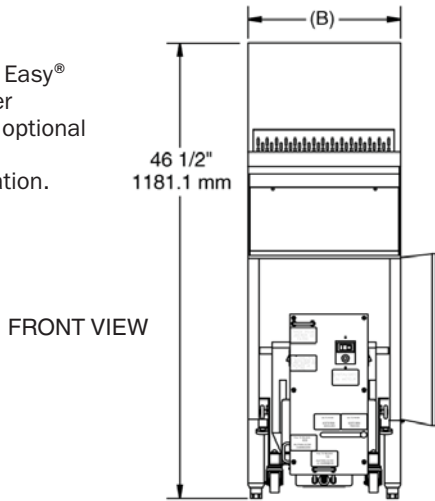

FRONT VIEW

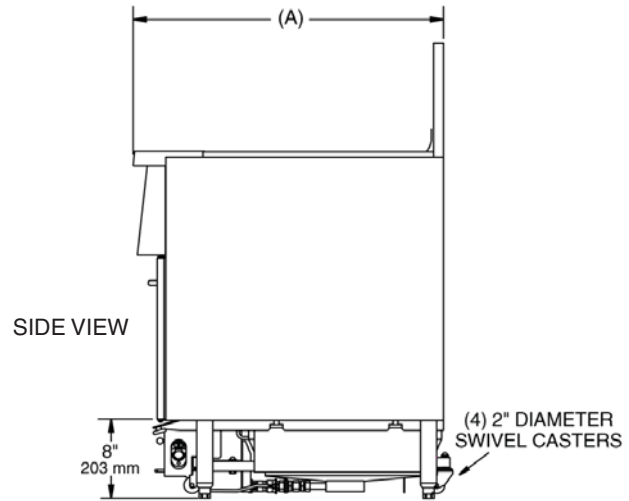

SIDE VIEW

SPECIFICATIONS

Performance - Central filter may be installed in a battery of up to six fryers (no more than three per side). Since only one fryer is out of operation at a time, filtration may be conducted at any time. Filtration time depends on the fryer size.

Filter Drawer - Removable drawer on bearing rollers with 20% more shortening capacity than largest fryer in battery. Filter drawer holds strainer basket, screen, hold down ring and spring loaded arms to hold paper in place. A sump and 3/8" pipe return the filtered oil to the closed pipe system.

Drain Valve - Rear drain with front release. 14" models to have 1" drain valve. 18" models to have 1-1/4" drain valve and 34x24 model to have two 1-1/4" drain valves.

Return Valve - Located above drain valve, it activates the Safe & Easy® Central Filter closed pipe return system.

Drain Pipe - 14" model to have 1-5/8", 18-24" models to have two 2", and 34x24 model to have two 1-1/4". To prevent blockage, no sharp bend 90 degree elbows or fittings are used.

Safety Switch - Provides 100% fryer shut off prior to filtration. Switch is activated when drain valve is opened.

Filter Paper - Exclusively designed to fit in filter tub.

Hold Down Ring - Keeps filter paper in place.

Pump - 1/3 horsepower, rated at pumping five gallons of oil per minute.

Hose and Wand - The hose and wand are provided for discarding shortening. Hose length varies with number and size of fryers.

Standard Accessories - Recessed dump station over filter with Stainless Steel perforated screen, one package of filter paper (60 sheets) and one carton of Acidox filter compound (60 packages).

Electrical Requirements - 120V, 5.6 amps for the pump circuit. The use of heat tape will add up to 3.1 amps depending on length of heat tape used.

Special Order Options may include Keep Krisp® Food Warmer mounted over preparation area, heat tape for solid shortening. 220V is available (special order - not certified).

MODEL	No. of Fryers	Oil Capacity	Voltage	HP	Amps	Filtrating Time	Fryer Height	(A) Fryer Depth	(B) Fryer Width	Weight
SE14CF	1	50 lbs.	120	1/3	5.6	1.5 min.	46 1/2"	32 5/8"	15 3/8"	170 lbs.
SE18CF	1	90 lbs.	120	1/3	5.6	2.5 min.	46 1/2"	36 5/8"	19 3/8"	190 lbs.
SE20CF	1	120 lbs.	120	1/3	5.6	3.5 min.	46 1/2"	38 5/8"	21 3/8"	210 lbs.
SE24CF	1	160 lbs.	120	1/3	5.6	4.5 min.	46 1/2"	42 5/8"	25 3/8"	230 lbs.
SE34x24CF	1	210 lbs.	120	1/3	6	6 min.	46 1/2"	42 5/8"	35 3/8"	250 lbs.

As continuous product improvement occurs, specifications may be changed without notice.

www.keatingofchicago.com

Safe & Easy® Central Filter