



# Safe & Easy® Filter

PROJECT \_\_\_\_\_

QUANTITY \_\_\_\_\_

ITEM NO. \_\_\_\_\_

**Standard Features:**

- ▶ Closed system provides safe and easy filtration
- ▶ Space saving design - filter fits completely under a Safe & Easy® fryer of the same size
- ▶ High speed pump
- ▶ Filters oil in less than 2 minutes
- ▶ Saves on oil costs
- ▶ Improves product quality



Casters on Fryer are Optional

The Safe & Easy® Filter is completely contained within the cabinet of a standard Safe & Easy® Keating Instant Recovery® Fryer. The Safe & Easy® Filter requires no additional kitchen space beside or behind the fryer.

**Easy to use**

The Safe & Easy® Filter is located directly under the fryer. After preparing the filter drawer, remove the filter cover, open the drain valve and allow all the oil to drain. Then switch on the filter pump and the filter does the rest with the filtration process. When the filtering process is complete, turn the pump to the off position and close the return valve.

**Less than 2 minutes**

Filtering oil is faster than ever with a Safe & Easy® Filter. If you have a battery of Keating fryers, the only fryer out of service is the one being filtered.

**Saves on oil costs**

Keating's patented fryer vessel design starts the filtration process by trapping natural sedimentation in the Cold Zone and preventing these particles from carbonizing and causing premature oil breakdown. When filtering with the Safe & Easy® Filter, oil passes through a crumb tray to remove large crumbs. Debris is further reduced with Acidox powder and filter paper, which removes free fatty acids and microscopic particles. This process extends the life of your oil.

**No messy clean-up**

The Safe & Easy® Filter is a closed system which requires limited direct contact with hot oil. A crumb basket, Acidox and paper in the bottom of the filter drawer trap all the crumbs and residue. Simply dump the crumbs and lift-out paper to complete the process.

**Proven safety features**

The Safe & Easy® Filter is designed to prevent contact with hot oil during filtering. There are no open containers in the aisle, no strainer cones or bags. The system is located within the filter and fryer cabinets to assure proper handling of the hot oil.



As continuous product improvement occurs, specifications may be changed without notice.

DATE \_\_\_\_\_

APPROVAL \_\_\_\_\_

SIGNATURE \_\_\_\_\_

[www.keatingofchicago.com](http://www.keatingofchicago.com)

Safe & Easy® Filter



## Safe & Easy® Filter

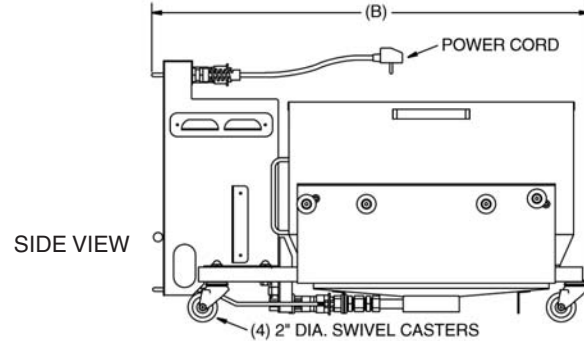
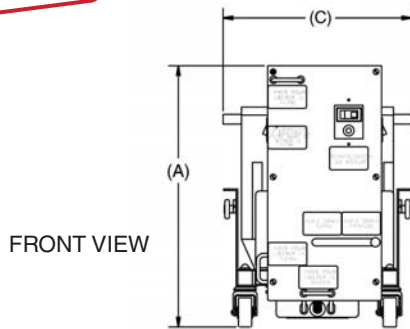

### SPECIFICATIONS

**Performance** - Safe & Easy® Filters may be installed in a battery of up to six fryers (no more than three per side). Since only one fryer is out of operation at a time, filtration may be conducted at any time. Filtration time is less than 2 minutes for a 14" fryer.

**Filter Drawer** - Filter drawer holds a strainer basket for large crumbs, a screen, a hold down ring for the filter paper and Acidox filter media. A sump and 5/8" pipe return the filtered shortening to the closed pipe system through a hands free "quick disconnect".

**Drain Valve** - Rear drain with front release. 1" drain valve on 14" models.

**Drain Pipe** - 1-5/8" drain pipe.

**Return Valve** - Activates the closed pipe return system on custom fry batteries. Return valve must be opened to operate the filter system.

**Safety Switch** - Provides 100% fryer shut off prior to filtration. Switch is activated when drain valve is opened.

**Pump** - 1/3 horsepower, rated at pumping five gallons of oil per minute.

**Hose and Wand** - The hose and wand are provided for discarding shortening. Hose length varies with number and size of fryers.

**Electrical Requirements** - 120V, 6 amp circuit. The filter is supplied with a Neoprene cord with a 3-prong grounded plug. Electric fryers require a separate electrical connection.

MODEL	Compatible with Fryer	Oil Capacity (lbs.)	Voltage	HP	Max Amp Draw	Filter Height (A)	Fryer Height	Filter Depth (B)	Fryer Depth	Filter Width (C)	Fryer Width	Weight
14SE	14AA	50	120	1/3	6	17 7/8"	46 1/2"	29 7/8"	32 5/8"	12 7/8"	15 3/8"	130 lbs.
14SE	14BB-G	50	120	1/3	6	17 7/8"	46 1/2"	29 7/8"	32 5/8"	12 7/8"	15 3/8"	130 lbs.
14SE	14TS-G	50	120	1/3	6	17 7/8"	46 1/2"	29 7/8"	32 5/8"	12 7/8"	15 3/8"	130 lbs.
14SE	14BB-E	50	120	1/3	6	17 7/8"	46"	29 7/8"	31 1/4"	12 7/8"	15 3/8"	130 lbs.
14SE	14TS-E	50	120	1/3	6	17 7/8"	46"	29 7/8"	31 1/4"	12 7/8"	15 3/8"	130 lbs.
14SE	14 IFM	50	120	1/3	6	17 7/8"	46"	29 7/8"	32 5/8"	12 7/8"	15 3/8"	130 lbs.
18SE	18AA	90	120	1/3	6	15 3/8"	46 1/2"	34 5/8"	36 5/8"	17"	19 3/8"	155 lbs.
18SE	18BB-G	90	120	1/3	6	15 3/8"	46 1/2"	34 5/8"	36 5/8"	17"	19 3/8"	155 lbs.
18SE	18TS-G	90	120	1/3	6	15 3/8"	46 1/2"	34 5/8"	36 5/8"	17"	19 3/8"	155 lbs.
18SE	18BB-E	90	120	1/3	6	15 3/8"	46"	34 5/8"	35 1/4"	17"	19 3/8"	155 lbs.
18SE	18TS-E	90	120	1/3	6	15 3/8"	46"	34 5/8"	35 1/4"	17"	19 3/8"	155 lbs.
18SE	18 IFM	90	120	1/3	6	15 3/8"	46 1/2"	34 5/8"	38 5/8"	17"	19 3/8"	155 lbs.
20SE	20AA	120	120	1/3	6	15 3/8"	46 1/2"	36 5/8"	38 5/8"	19"	21 3/8"	160 lbs.
20SE	20BB-G	120	120	1/3	6	15 3/8"	46 1/2"	36 5/8"	38 5/8"	19"	21 3/8"	160 lbs.
20SE	20TS-G	120	120	1/3	6	15 3/8"	46 1/2"	36 5/8"	38 5/8"	19"	21 3/8"	160 lbs.
20SE	20BB-E	120	120	1/3	6	15 3/8"	46"	36 5/8"	37 1/4"	19"	21 3/8"	160 lbs.
20SE	20TS-E	120	120	1/3	6	15 3/8"	46"	36 5/8"	37 1/4"	19"	21 3/8"	160 lbs.
20SE	20 IFM	120	120	1/3	6	15 3/8"	46 1/2"	36 5/8"	38 5/8"	19"	21 3/8"	175 lbs.
24SE	24BB-G	160	120	1/3	6	15 3/8"	46 1/2"	40 5/8"	42 5/8"	23"	25 3/8"	175 lbs.
24SE	24TS-G	160	120	1/3	6	15 3/8"	46 1/2"	40 5/8"	42 5/8"	23"	25 3/8"	175 lbs.
24SE	24BB-E	160	120	1/3	6	15 3/8"	46"	40 5/8"	41 1/2"	23"	25 3/8"	175 lbs.
24SE	24TS-E	160	120	1/3	6	15 3/8"	46"	40 5/8"	41 1/2"	23"	25 3/8"	175 lbs.
34x24SE	34x24BB-G	210	120	1/3	6	15 1/2"	46 1/2"	40 5/8"	42 5/8"	32 1/4"	35 3/8"	200 lbs.
34x24SE	34x24TS-G	210	120	1/3	6	15 1/2"	46 1/2"	40 5/8"	42 5/8"	32 1/4"	35 3/8"	200 lbs.
34x24SE	34x24BB-E	210	120	1/3	6	15 1/2"	46"	40 5/8"	42 5/8"	32 1/4"	35 3/8"	200 lbs.
34x24SE	34x24TS-E	210	120	1/3	6	15 1/2"	46"	40 5/8"	42 5/8"	32 1/4"	35 3/8"	200 lbs.

As continuous product improvement occurs, specifications may be changed without notice.

[www.keatingofchicago.com](http://www.keatingofchicago.com)

Safe & Easy® Filter