

SERVICE INSTRUCTIONS

Part # 037670

www.keatingofchicago.com

KEATING
OF CHICAGO, INC.®

1-800-KEATING

FLEXIBLE TUBING to HARD PIPING INSTALLATION INSTRUCTIONS - for MOTOR/PUMP PART# 055173

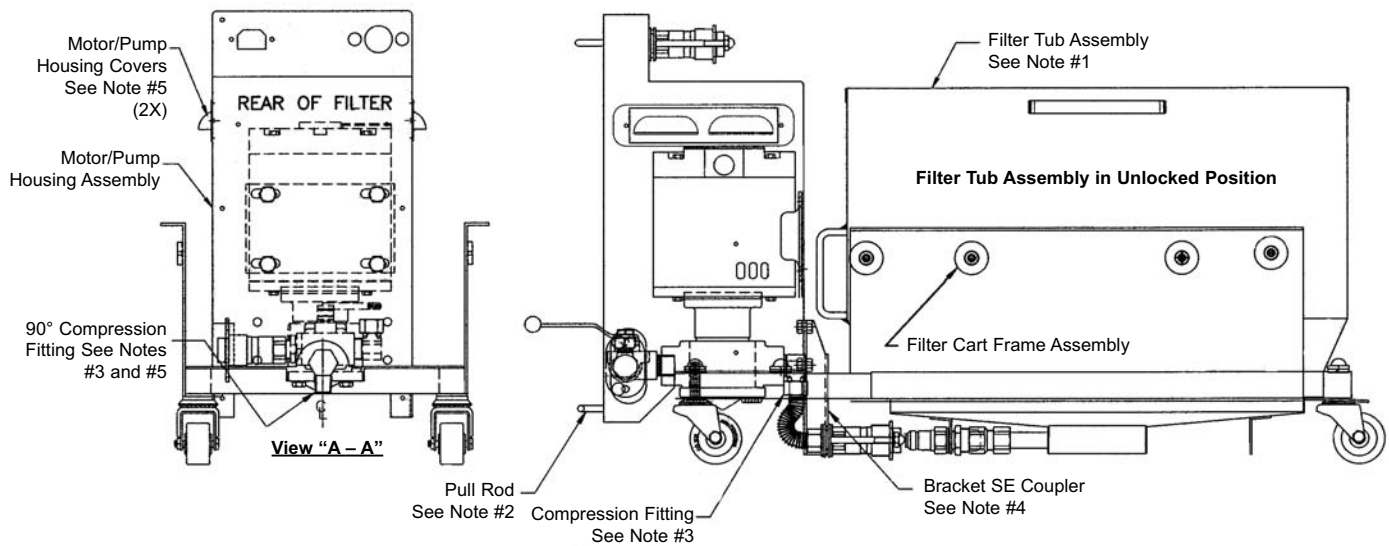

Caution:

Make Sure Safety Glasses are Worn

Notes:

1. Drain and clean all oil from filter tub assembly. Remove filter tub assembly from filter cart frame assembly. This assembly will be turned over (upside down), for replacement of parts and adjustment to mating part on motor mount housing assembly.
2. Remove pull rod and set aside; this part will be used later.
3. Loosen compression fitting at pump output. Do not remove 90° fitting from pump.
4. Remove (4) bolts holding bracket SE coupler. This assembly will be replaced with new parts in kit. The bracket and flex tubing with quick connect are to be discarded.
5. Inspect 90° compression fitting on the pump as shown in View A – A. If the fitting is not on center line of the radius on the pump mount housing assembly as shown, use a #23 or #24 drill to remove pump housing covers (2) as shown in view A – A, to gain easier access to the top bolts holding the motor/pump. Loosen (4) bolts on motor/pump to center 90° fitting as best as possible. These covers will be re-assembled with parts in the kit. After adjustments are made to the motor/pump to center 90° compression fitting as shown in view A – A, tighten the (4) bolts for the motor/pump.

Use these Service Instructions for the following Kit part #'s:

057117	SE14
057118	SE18
057119	SE20
057120	SE24

FLEXIBLE TUBING to HARD PIPING INSTALLATION INSTRUCTIONS - for MOTOR/PUMP PART# 055173

(CONTINUED)

Operation #2 Re-Assembly

Notes:

1. Remove filter tub from motor/pump housing assembly and set aside. On 18, 20 and 24 models only, remove pipe nipple 3/8" NPT x 1" and discard. Replace with pipe nipple 3/8" NPT x 1-1/2" (item B). See view A for proper dimensions from back of sump to front of quick connect. On 14" filter tub, see view A for proper dimensions from back of sump to front of quick disconnect. Place the filter tub into the filter cart assembly. Release the filter tub away from the pump housing as shown in side view. Turn the entire assembly upside down as shown in view B. This step is critical to insure proper alignment between the motor housing quick connect and the filter tub quick connect. Use table or bench, making sure the motor/pump housing is off of the table/bench.

CAUTION: IF FILTER ASSEMBLY IS PLACED UPSIDE DOWN ON A TABLE OR BENCH, MAKE SURE UNIT IS SECURE, SO AS NOT TO SLIDE OFF TABLE/BENCH.

2. Slide item C into position to connect the compression fitting on the pump's 90° fitting. **DO NOT TIGHTEN COMPRESSION FITTING AT**

Your Kit Includes (items with * may not be included):

Item	Part #	Qty	Description
A	-----	-	-----
*B	056990	1	Pipe Nipple 3/8 NPT 1-1/2 SS-304
C	056907	1	Bracket Ass'y Haight Baker Pump
D	020101	8	Nut 5/16 Hex Head Serrated Flang
E	017142	4	Screw 5/16-18 x 3/4 Hex Head
F	015227	2	Nut 1/4" Acorn S/S
G	004611	4	Screw #10 x 3/8 Sheet Metal Pan HD.
*I	037672	A/R	Sealant Locktite 262 (.017 oz.)
J	056765	8	Washer Flat 7/16" ID x 1.00 OD x .078 THK.
K	017481	4	Screw 5/16 -18 x 1-3/4 Hex HD SS
L	X	1	Reinforcement Bracket
M	015158	2	Acorn Nut 5/16-18 SS
N	052733	2	Washer 11/32 ID x 3/4 OD
O	000290	2	Washer, Lock 5/16" Split

THIS TIME. Attach item C, to the pump housing with items D and E. **DO NOT TIGHTEN COMPLETELY AT THIS TIME.** Play must be present for proper alignment of pump housing connect and filter tub quick connect. Slide the filter tub assembly forward until the quick connects are engaged. Tighten items D and E completely. Tighten compression on item C. Remove (2) bolts and washers "K" and add reinforcement bracket "L." Use longer (2) bolts provided and discard old ones. For 20 and 24 models, add items D and K to reinforcement bracket and tighten until snug on motor mount housing assembly (See Bottom View).

3. Attach filter tub pull rod handle using item F and I.
4. Attach the pump mount covers using item G.
5. Inspect for spacers between casters and filter cart assembly. If none are present, remove casters and place item J (2) on the casters threaded stem and reassemble using existing fasteners and item I.
6. Carefully turn filter assembly to the upright position. Release the filter tub pull rod and check for proper disconnect. Reconnect the filter tub to the motor mount housing using handles. If the assemblies do not connect properly, it will be necessary to verify notes above were followed correctly.

7. Fill filter tub with oil per users manual, cycle oil to check for leaks at fittings, correct if needed.

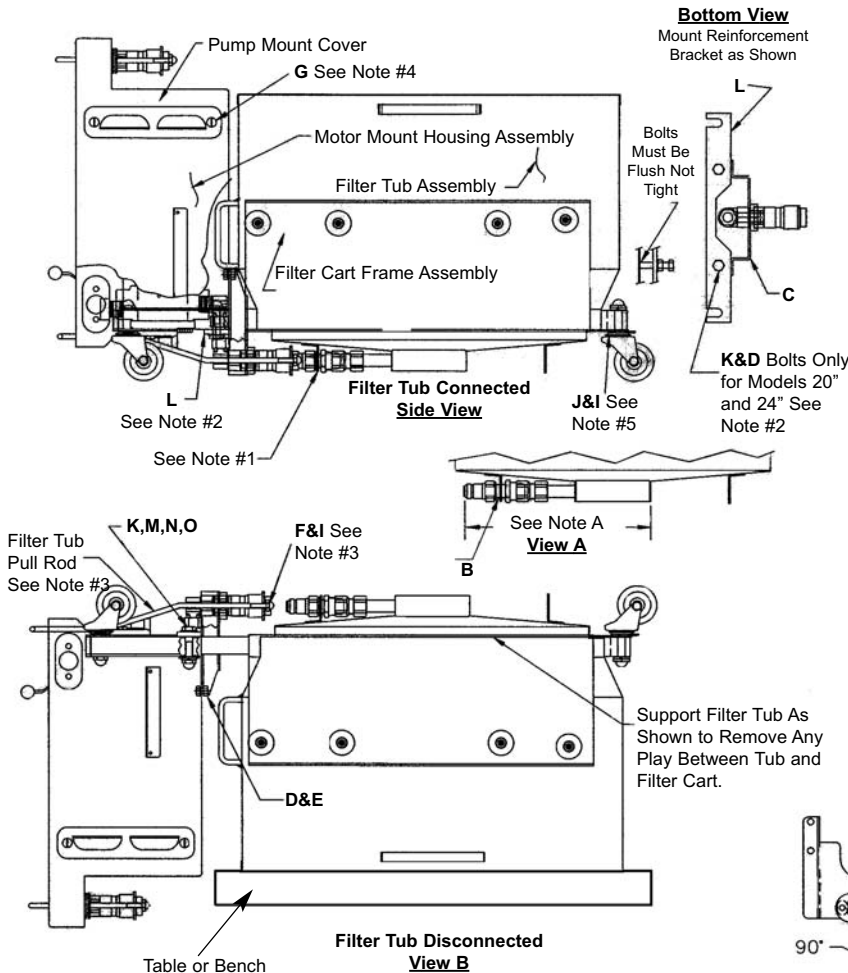

Note A Dimensions

9-5/16" for 14" Filter
 11-3/8" for 18" Filter
 12-3/8" for 20" Filter
 14-3/8" for 24" Filter