

SERVICE INSTRUCTIONS

www.keatingofchicago.com

KEATING
OF CHICAGO, INC.®

1-800-KEATING

CONVERSION OF FRYER VESSEL TO UNI-POT MODELS

A fryer vessel should be kept shiny and clean at all times. A clean fryer vessel will not only provide well prepared food products, but will also save energy and oil costs.

NOTE: Before attempting to replace. Verify that the vessel needs to be replaced. Familiarize yourself with the replacement process. Check the new vessel before disassembling the fryer.

NOTE: If possible, remove the fryer from the immediate cooking area to a less congested area of the restaurant for service.

NOTE: Always install new radiants supplied when installing a new or rebuilt fryer vessel.

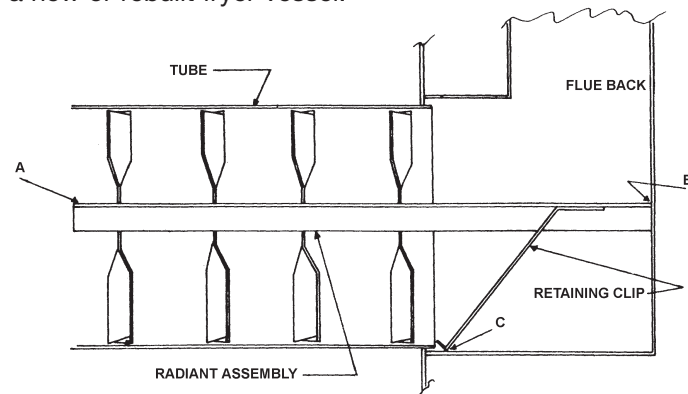

1. To install assembly, insert the end with the retaining clip in the tube first. Make sure that the end of the clip "C" is bent below the bottom of the radiant fins.
2. Push the assembly back as far as it will go until the rear end of angle bar is against the flue back at "B".
3. As the assembly is inserted, make sure that the fins are not bent out of perpendicular with the radiant angle bar.

Removal:

1. Disconnect electric power source. (except for AA and CMG models).
2. Turn off gas.
3. Drain oil into approved container and set aside.

Fryer vessel being removed.



4. Removal of components:
 - a. Remove flame switch bulb.
 - b. Remove control panel.
 - c. Remove control panel back.
 - d. Remove thermostat bulb from vessel.
 - e. Remove Hi-Limit control bulb from vessel.
 - f. Remove burners.
5. Loosen union in tailpiece assembly.
6. Remove gas manifold with support brackets from vessel by removing four screws and lockwashers joining brackets to sides of vessel. Leave constant and runner pilot tubing and gas manifold connected to manifold brackets.
7. Remove splashback screws, drill out pop rivets and lift splashback from fryer.
8. Remove two screws in vertical canopy trim pieces, firmly tap downward on canopy to loosen it and lift canopy from fryer.
9. To remove fryer vessel, grasp top of flue and lift it forward, then lift fryer vessel up.
10. Remove drain valve from fryer vessel.
11. Remove flue from fryer vessel by removing six screws out of tabs. Inspect flue for cracks or damage and replace if necessary.

CONVERSION OF FRYER VESSEL TO UNI-POT MODELS

Page 2

Replacement:

1. Drop new uni-pot in cabinet with front plate, flue hold down bar brackets, and drain valve attached. (Refer to drawing "A" attached) NOTE: The front plate is an additional part and must be installed on the uni-pot. Failure to do so will void the warranty. NOTE: The front plate cannot be used on counter model fryers. On some older counter models the front brackets may have to be removed. (Refer to Drawing "B" attached)
2. Slide manifold back and position about 3/8" in front of its previously installed location.
3. Break ears off sides of burners with hammer before inserting on unit.
4. Place burner stems over orifice spuds on manifold to help align.

NOTE: Burners may sit slightly low over front plate openings. If so, hold each burner up to proper position on front plate aligning ports on burners over the oval holes and tighten the square head screw on burner stem base to orifice spud on manifold to prevent burner from falling down.

5. Attach burner hold down bar to uni-pot brackets keeping burners alighted over oval holes. Tighten nuts.
6. When burners are secured against front plate, loosen square head screws on burner stems, push manifold up tight against bottom of stems, retighten screws. Lastly, retighten the bolts holding the gas manifold to the cabinet side brackets.
7. If necessary, reattach the heat deflector to the burner hold down bar using the 2 flat head sheet metal screws provided.
8. To reconnect the union of the gas inlet pipe, it may be necessary to remove the 2 screws holding the hat channel (bracket the tail pipe goes through) to the back of the cabinet so it can be pulled forward to make connection. If needed, the screw hole in the hat channel and cabinet back can be drilled out so a small bolt can be inserted to replace the screws. Washers can be used as spacers between the cabinet back and hat channel to fill in the gap between the two.

9. Replace Thermostat

Thermostat Bulb Positioning

Keating's patented thermostat application is accurate within 2°F of the dial setting between 250°F and 350°F. This accuracy is attained only if the thermostat bulb is placed properly against the heat transfer tube. A single thickness of paper should be pulled through between the tube and the bulb with medium resistance to quickly and accurately test for proper bulb placement and pressure.

- a. If the bulb is too tight, the paper will either not pull through or it will tear. A fryer with a thermostat bulb that is too tight will short cycle.

Short Cycle: The thermostat will cycle rapidly while the fryer is in the idle mode; the temperature will be erratic and fuel will be wasted.

- b. If the bulb is too loose, the paper will slip through with little or no resistance. A fryer with a thermostat bulb that is too loose will overshoot or cycle long.

Overshoot: The thermostat takes a long time to cycle and then misses its preset temperature by 20°F - 40°F yielding a poor quality product.

Thermostat Bulb Positioning

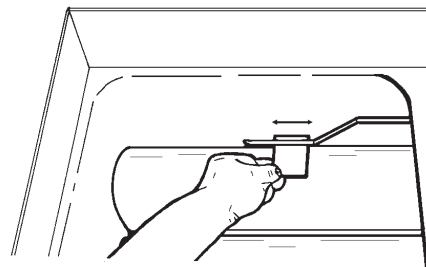

10. Replace control panel back.
11. Replace control panel.
12. Replace flame switch bulb.

SERVICE INSTRUCTIONS

www.keatingofchicago.com

KEATING
OF CHICAGO, INC.®

1-800-KEATING

CONVERSION OF FRYER VESSEL TO UNI-POT MODELS

Page 3

Insert bulb through holes in bracket and slot in clip. With FSC bulb Ferrule on runner pilot tube side of clip, press clip down hooking it over bottom end of bracket.

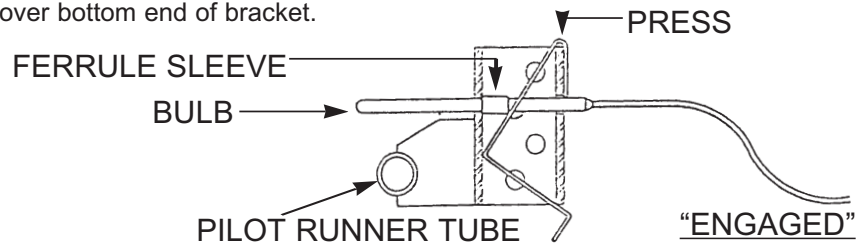

Fasten clip in place using screw "A" and/or screw "B" as shown.

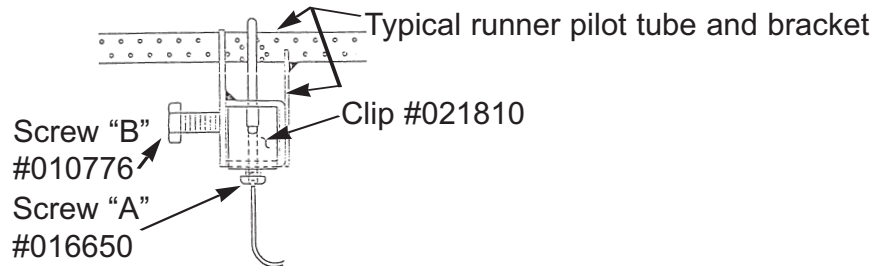

13. Connect electric power source (except for AA and CMG models), turn on gas and pilots.
14. Boil-out fryer.
15. Refill fryer with oil to the "Fill Level" line.
16. Start and preheat fryer, and calibrate

SERVICE INSTRUCTIONS

www.keatingofchicago.com

KEATING
OF CHICAGO, INC.®

1-800-KEATING

Page 4

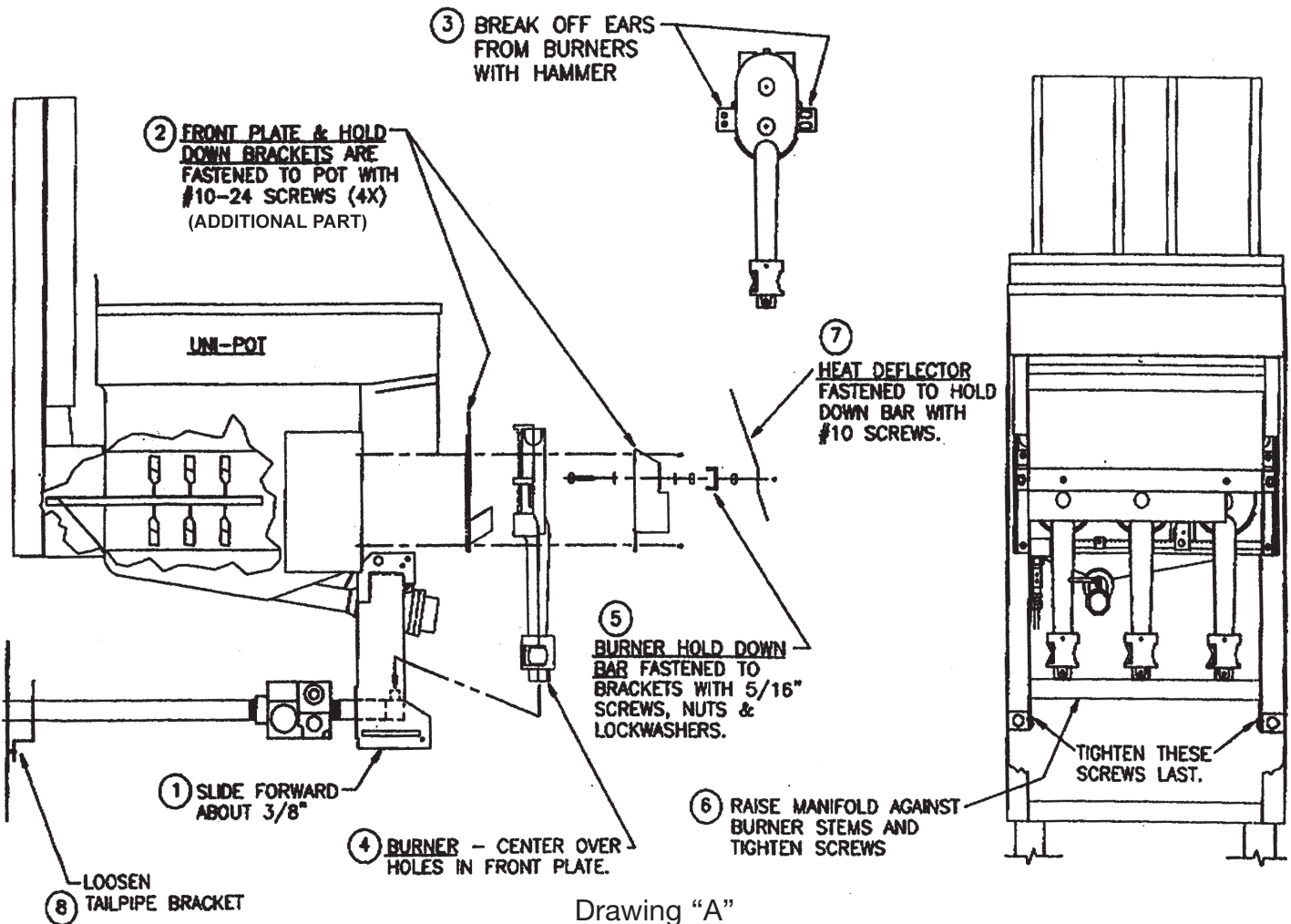

To remove brackets from pot, grind off the (4) welds holding it to the pot. Care must be taken to avoid grinding through the side of the pot. Remove brackets.

